

Code Requirements and Fire Stopping for Over-the-Deck Venting of Stone Coated Metal Roofs.

The International Building Code (Section 1203.2), the International Residential Code (Section 806) and the International Wildland-Urban Interface Code (Sections 504.10, 505.10 and 506.4) all allow attic venting with the vent openings covered with corrosion-resistant wire mesh with openings no greater than ¼". The International Wildland-Urban Interface Code, 2006 edition, is much more restrictive in terms of the location of ventilation openings for the attic and it also specifically requires in Section 504.2: "For roof coverings where the profile allows a space between the roof covering and the roof decking, the space at the eave ends shall be fire stopped to preclude entry of flames or embers." Fire stopping can consist of 2-inch nominal dimension lumber (Section 504.3).

Research on stone-coated metal roofing systems conducted at Oak Ridge National Laboratory (ORNL) found energy savings benefits from air movement that develops in the space between the metal roof covering and deck over which it is installed. (see reference paper) The normal installation practice used for stone coated metal roofing allows for air between the roof and the deck to exit from the space through a vent at the ridge of the roof. According to ORNL, similar venting of the attic space has been required by the Federal Housing Administration (FHA 1942) since 1942.

The ORNL research project included the traditional installation practice of using 2" x 2" batten placed on the deck at the eave of roofs covered with stone-coated metal roof coverings. This practice meets the most restrictive Code requirements. In the tests performed by ORNL, all the test decks except one had either a 2" x 2" batten installed over the deck at the eave, or in the cases where a 1" x 4" counterbatten was used, a metal fascia covering was used to cover the build-up resulting from installing the battens over counter-battens. As shown in Figure 1, this metal fascia completely covered the opening created by the counterbatten.

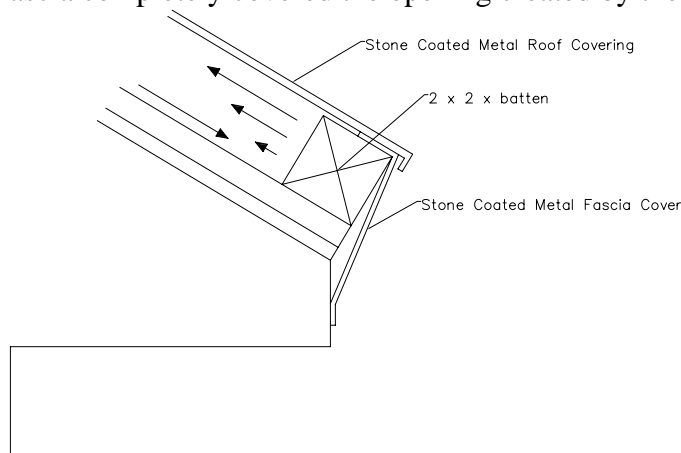

Figure 1. Fascia covering at eave of tested roof panels

To meet the requirements of the International Wildland-Urban Interface Code (Sections 504.10, 505.10 and 506.4) a further 1" x 4" would need to be placed under the 2" x 2" battens and behind the metal fascia covering at the eave, thereby completely blocking the space behind the metal fascia covering with minimum 2-inch nominal dimension lumber. Installation of this extra 1" x 4" behind the metal fascia covering will not in any way change the results of the tests performed by ORNL because the air flow in the space between the stone-coated metal roof covering and the deck is caused by natural convection and is not in any way dependent on having an opening at the eave. In fact, on the one test lane where a deliberate opening at the eave was created ORNL recorded that this fascia opening did not change the air flow in the space, or change the results of the testing, when compared to an identical roof product installed with no opening in the fascia.

Since the normal stone-coated metal roof installation, with metal fascia covering the eave, was provided on all the decks tested, except for the one deliberate opening, it can be concluded that the air space above the deck will provide sufficient ventilation to achieve the reductions in heat transmission to and from the attic that ORNL measured, even though there is no opening at the eave between the deck and the roof covering.

Presented By:
Metal Construction Association (MCA)
4700 West Lake Avenue
Glenview, IL 60025-1485

© 2007 Metal Construction Association. All rights reserved.

Reference:

Miller, W.A., "The effects of Infrared-Blocking Pigments and Deck Venting on Stone-Coated Metal Residential Roofs", ORNL/TM-2006/9, Prepared for the US Dept. of Energy Buildings Technology Program, Marc LaFrance, Program Manager, and the Metal Construction Association, January 2006.

Acknowledgements:

The Metal Construction Association thanks John Miller of Decra Roofing Systems for being the principle author of this white paper and also thanks Dr. William Miller of Oak Ridge National Laboratory for his research on this subject.